

**SECTION A [40 MARKS]**  
**ANSWER ALL THE QUESTIONS**

**Question 1**

**[40]**

For each question there are **FOUR** responses: **A, B, C** and **D**. Choose the corresponding letter of your response and **CIRCLE** it neatly. **NO** score will be awarded if you circle more than **ONE** letter.

i. Which of the following matrices is an identity matrix?

A  $\begin{bmatrix} 1 & 1 \\ 1 & 0 \end{bmatrix}$

B  $\begin{bmatrix} 1 & 0 \\ 0 & 1 \end{bmatrix}$

C  $\begin{bmatrix} 0 & 1 \\ 1 & 0 \end{bmatrix}$

D  $\begin{bmatrix} 1 & 1 \\ 1 & 1 \end{bmatrix}$

ii. Penjor needs to find two poles of the right height to support the tent which has the total surface area of  $136 \text{ m}^2$ . What would be the height of the pole?

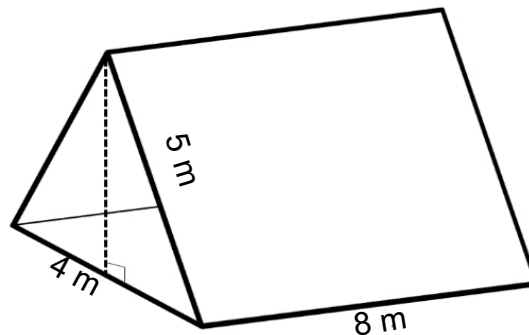

- A 32 m  
B 16 m  
C 6 m  
D 3 m

iii. Which of the following pairs of quadratic functions are equivalent?

A  $f(x) = x^2 - 5x - 6$  and  $h(x) = (x - 2)(x - 3)$

B  $f(x) = 2x^2 + 4x + 2$  and  $h(x) = (x + 1)^2 + 2$

C  $f(x) = x^2 + 6x + 9$  and  $h(x) = (x + 3)^2$

D  $f(x) = x^2 - 4x + 4$  and  $h(x) = (x + 2)^2$

iv. Pema saved Nu 2,500 for her summer break. She plans to spend Nu 500 each week. Which of the following linear models represents the total amount of money Pema will have left after a week?

A  $M(w) = 2500 - 500w$

B  $M(w) = 2500w - 500$

C  $M(w) = 2500 + 500w$

D  $M(w) = 2500w + 500$

v. The missing dimension of the rectangular frame is

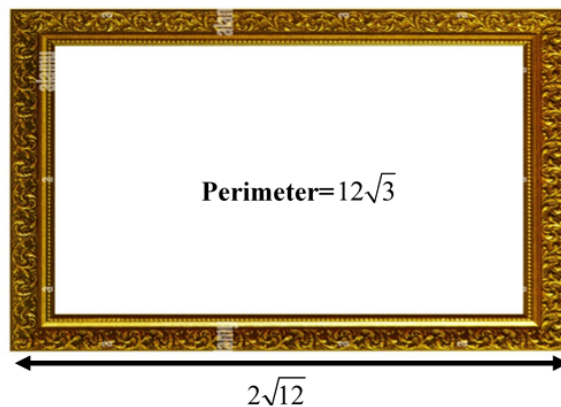

A  $\frac{\sqrt{3}}{4}$ .

B  $2\sqrt{3}$ .

C  $3\sqrt{2}$ .

D  $\sqrt{12}$ .

vi. For the following adjacency matrix, the network is represented by

$$\begin{array}{c}
 A \quad B \quad C \\
 A \begin{bmatrix} 0 & 2 & 0 \end{bmatrix} \\
 B \begin{bmatrix} 0 & 0 & 1 \end{bmatrix} \\
 C \begin{bmatrix} 1 & 0 & 0 \end{bmatrix}
 \end{array}$$

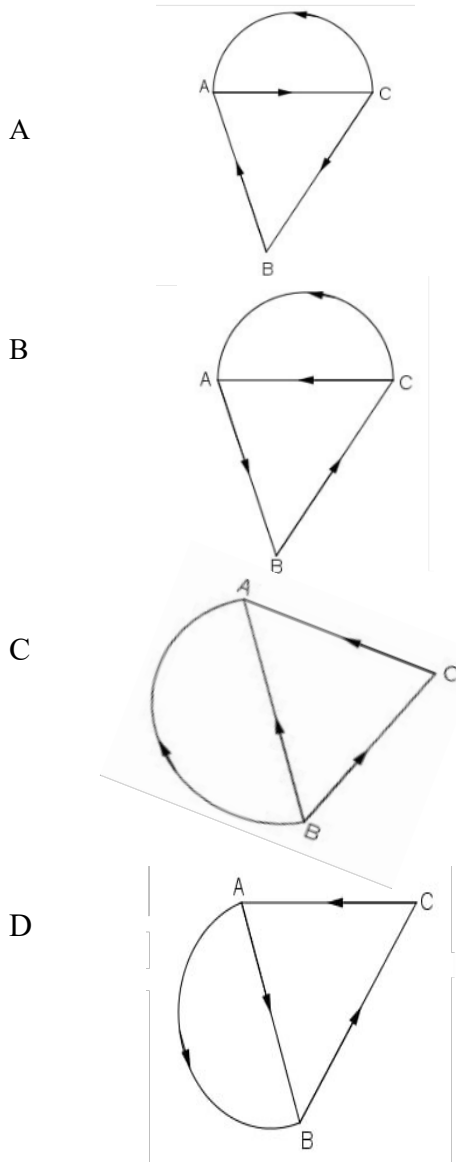

vii. An investor buys 200 shares with a face value of Nu 50 each. At the end of year the investor received Nu 3,500 from the share. What is the rate applied?

- A 25%
- B 30%
- C 35%
- D 45%

- viii. Ram is trying to determine the orientation of a ramp on a hillside. He knows that the sine of the angle  $\theta$  between the ramp and the ground is  $-\frac{1}{\sqrt{2}}$  and the tangent of the angle  $\theta$  is 1. In which quadrant does the angle  $\theta$  lie?
- A First quadrant
  - B Third quadrant
  - C Second quadrant
  - D Fourth quadrant
- ix. A gardener observes the growth of her plant as shown in the table:

Week	Height (cm)
1	10
2	12
3	14
4	16

- Is the height of the plant a function of the week?
- A Yes, because the height increases over time.
  - B Yes, because each week has a unique height.
  - C No, because the height depends on external factors.
  - D No, because the height can be the same in different weeks.
- x. The location of the circumcenter in a right angle triangle is
- A inside the right angle triangle.
  - B outside the right angle triangle.
  - C at the mid-point of the hypotenuse.
  - D at the vertex of the right angle triangle.

- xi. You are given an angle  $\frac{5\pi}{6}$  rad. Select the graph that correctly represents this angle in standard position.

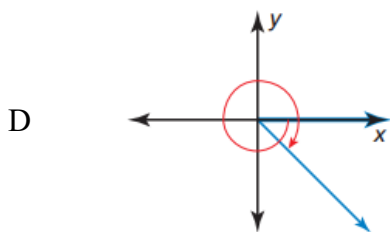
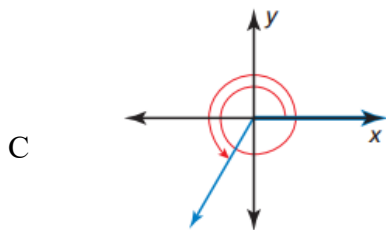
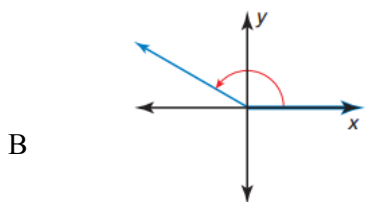
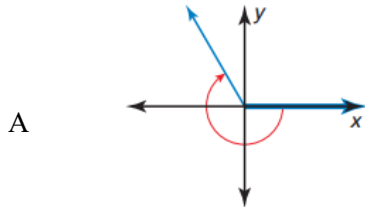

- xii. The equation  $y = x^2$  undergoes a transformation where it is shifted 3 units to the right and 2 units up. What is the new equation after this transformation?

A  $y = (x - 3)^2 + 2$

B  $y = (x + 3)^2 - 2$

C  $y = (x + 3)^2 + 2$

D  $y = (x - 3)^2 - 2$

- xiii. The correlation coefficient between independent and dependent variable in the scatter plot shown below is

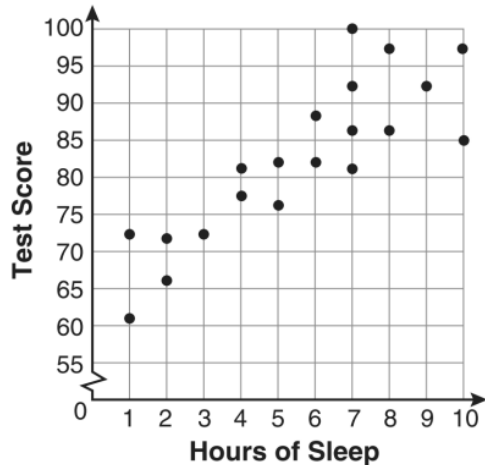

- A Close to -1.  
B Close to 1.  
C 1.  
D -1.
- xiv. The radius of a cylinder is doubled and the height unchanged. The ratio between the volumes of the new cylinder to original cylinder is
- A 1 : 2.  
B 1 : 3.  
C 1 : 4.  
D 1 : 8.
- xv. For the equation  $x^2 - 7x + 10 = 0$ , the  $x$ -intercepts are
- A  $x = 2$  and  $x = 5$ .  
B  $x = -2$  and  $x = 5$ .  
C  $x = 2$  and  $x = -5$ .  
D  $x = -2$  and  $x = -5$ .

- xvi. If M is the set of students who study music and S is the set of students who play sports as represented in the Venn Diagram. Determine the probability that if a student is selected at random, he or she will study music given that he or she plays a sport.

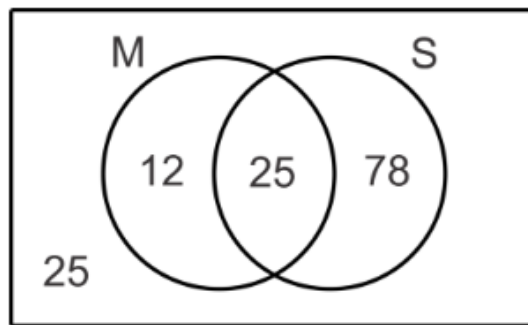

- A  $\frac{78}{140}$   
B  $\frac{78}{103}$   
C  $\frac{25}{103}$   
D  $\frac{37}{140}$

- xvii. Determine the volume of the given shape.

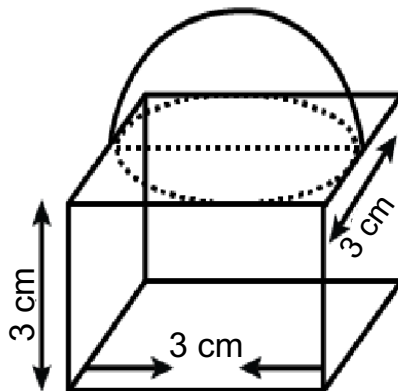

- A  $56.52 \text{ cm}^3$   
B  $48.45 \text{ cm}^3$   
C  $42.39 \text{ cm}^3$   
D  $34.08 \text{ cm}^3$

xviii. Which of the following groups of the figures have both horizontal and vertical mirror symmetry?

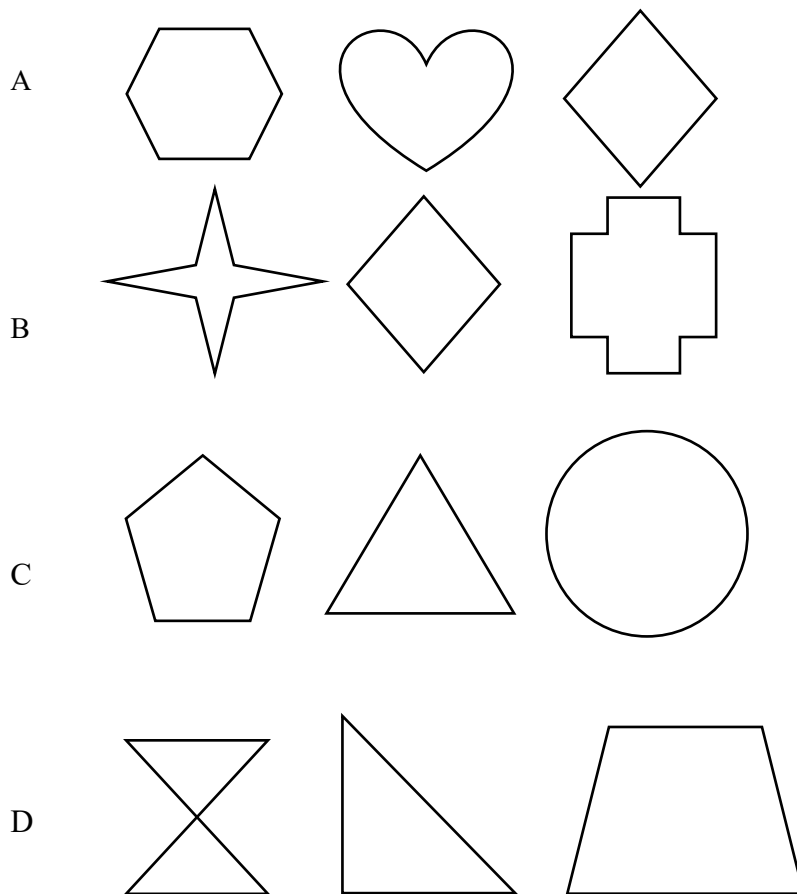

xix. The following shapes have the same volume of  $350 \text{ cm}^3$ .

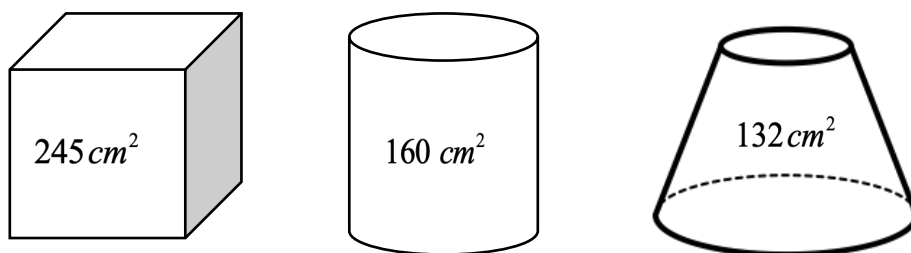

The correct order arranged from the least efficient to the most efficient is

- A Cube, Cylinder, Truncated cone.
- B Cube, Truncated cone, Cylinder.
- C Truncated cone, Cube, Cylinder.
- D Truncated cone, Cylinder, Cube.

- xx. If a histogram shows a right-skewed distribution, how would this be represented in the corresponding box plot?
- A The median will be centered, the whiskers will be of equal length.
  - B The median will be closer to the lower quartile, the left whisker will be longer.
  - C The median will be closer to the upper quartile, the left whisker will be longer.
  - D The median will be closer to the lower quartile, the right whisker will be longer.

**SECTION B [60 MARKS]**

**ANSWER ANY SIX QUESTIONS**

**Question 2**

- a) Complete the table for the value of  $p, q, r$  and  $s$ .

[2]

Angle	$0^\circ$	$30^\circ$	$45^\circ$	$60^\circ$	$90^\circ$
<b>sin</b>	0	$\frac{1}{2}$			
<b>cos</b>				$\frac{1}{2}$	
<b>tan</b>		..... $p$ .....	1		
<b>cosec</b>				..... $q$ .....	
<b>sec</b>		..... $r$ .....			
<b>cot</b>					..... $s$ .....

<p><math>p =</math></p> <p><math>q =</math></p> <p><math>r =</math></p> <p><math>s =</math></p>	
---	--

- b) A man borrowed Nu 20,000 and repaid the loan at the end of 4 years with a single payment of Nu 35,608. What interest rate was charged if compounded semi-annually? [3]

--	--

- c) The given box and whisker plots represents the income from source A and source B. [2]

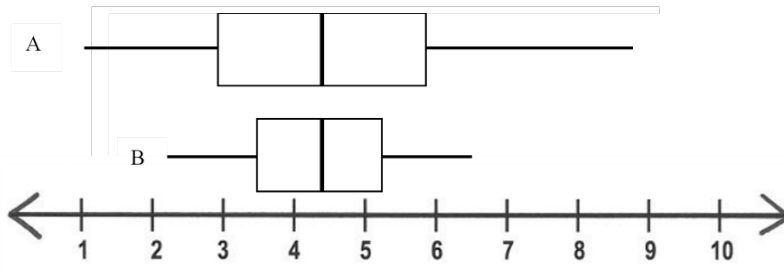

Which source appears to be more reliable? Explain.

--	--

- d) The sum of two consecutive numbers is 36 more than the difference between the numbers. What are the numbers? [3]

--	--

### Question 3

- a) Describe how the occurrence of a dependent event affects the probability of another event occurring. [1]

--	--

- b) Determine surface area of the given shape. If a sphere has the same surface area as the rectangular prism, what is the diameter of the sphere? [3]

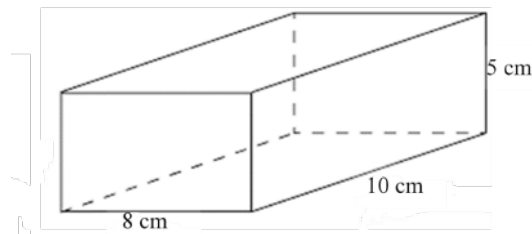

--	--

- c) Let  $x$  and  $y$  be two numbers. Use the statement given in the box and find the solutions.

[3]

$y$  is  $\frac{1}{3}$  more than 4 times the value of  $x$

The difference of  $3y$  and  $2x$  is 1

--	--

- d) Complete each shape so that  
 i. it has rotational symmetry of order 4.

[2]

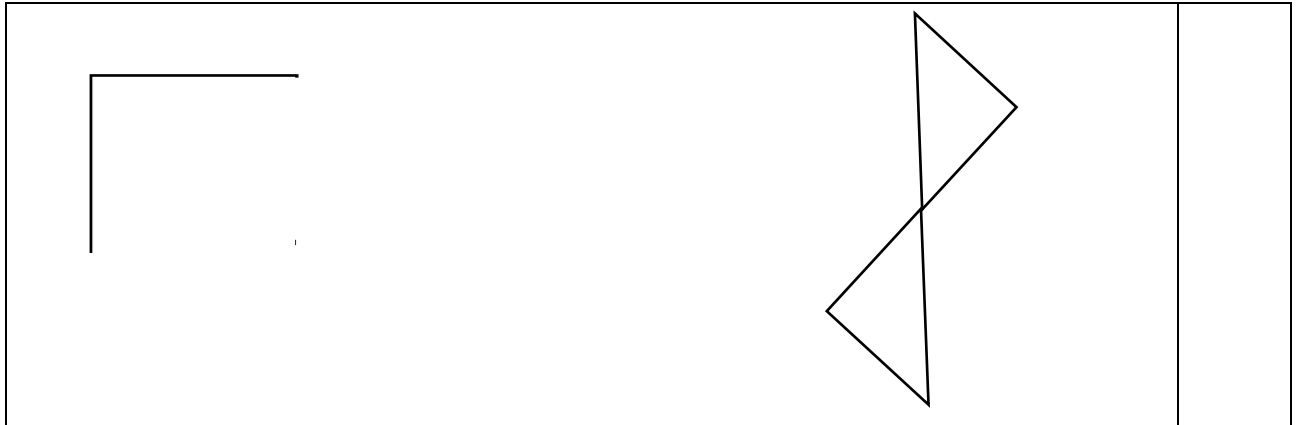

- ii. the star has nine points, shade six points to make a pattern with order of turn symmetry 3.

[1]

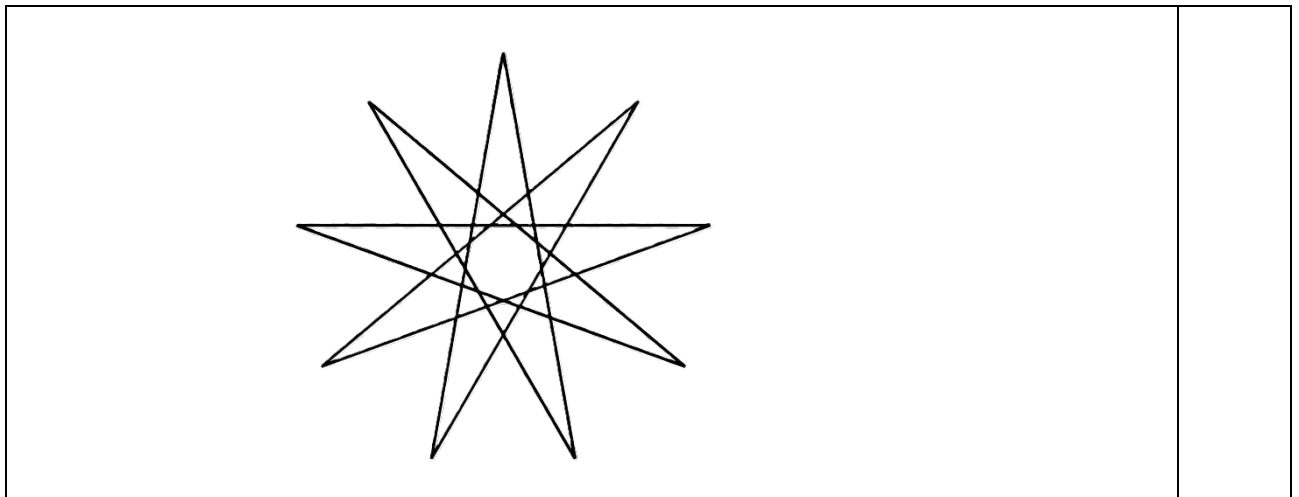

**Question 4**

- a) The 12 letters of the word “MEASUREMENTS” are written on 12 cards and placed in a bag. Two cards are drawn from the bag, one after the other.

- i. You draw a card with the letter E and then replace it. What is the probability that you will draw a card with the letter E on the second draw?

[0.5]

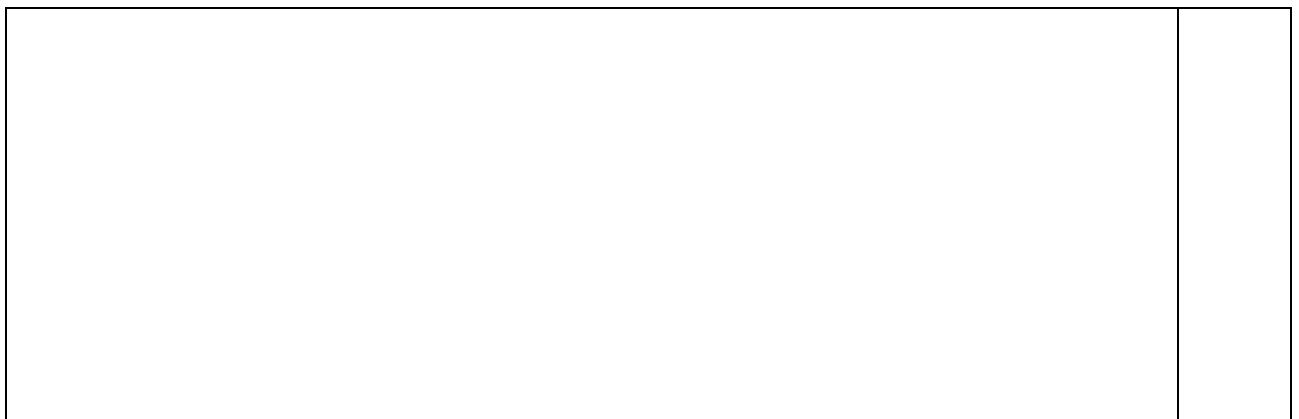

- ii. You draw a card with the letter E and do not replace it. What is the probability that you will draw a card with the letter E on the second draw? **[0.5]**

--	--

- iii. Which is dependent, the two events in question i or the two events in question ii. **[1]**

--	--

- b) Construct  $\Delta ABC$ , where  $AB = 7$  cm,  $\angle A = 45^\circ$  and  $\angle B = 60^\circ$ . Then, construct a circle that passes through all three vertices of  $\Delta ABC$ . **[3]**

--	--

- c) The school football team committee submitted equipment list to participate in the Bhutan Higher Secondary School football competition 2024.

[2]

**Equipment Required**

20 uniforms

40 balls

25 stockings

The price of a uniform at **Shop A** is Nu 950, a ball costs Nu 400, and a pair of stockings costs Nu 250. At **Shop B**, the price of a uniform is Nu 800, a ball costs Nu 500, and a pair of stockings costs Nu 350. Use matrix multiplication to calculate the total cost of these items from both shops. Determine from which shop you should buy the equipment if you want to minimize the total cost.

--	--

- d) A utility van travels  $7\sqrt{3}$  km east from Gelephu, then  $4\sqrt{6}$  km north to reach Jigmecholing. Calculate the distance to help the driver find a more fuel efficient route between the Gelephu and Jigmecholing. [2]

--	--

- e) For what values of  $m$  will the simplified form of the expression  $\sqrt{2^m}$  contain a radical? Explain. [1]

--	--

**Question 5**

- a) In a class of 20 students, test scores are normally distributed except for one outlier score of 98. How does this outlier affect both the mean and median of the test scores? [2]

--	--

b)

i. If  $\sin \theta = \frac{1}{3}$ , then find the value of  $2 \cot^2 \theta + 2$ .

[3]

--	--

ii. Why is  $\cos \theta = \frac{5}{4}$  not a feasible value?

[1]

--	--

- c) An object is dropped from a 64 feet tall building. The height of the object above the ground after  $t$  seconds is given by  $h(t) = 64 - 16t^2$ . [2]

If  $t = 1$  second, can the object reach the ground? If not, what is the time required for the object to reach the ground?

--	--

- d) Graph the function  $f(x) = -(x+1)(x-3)$ . [2]

--	--

**Question 6**

a) Determine slope and y- intercept.

[2]

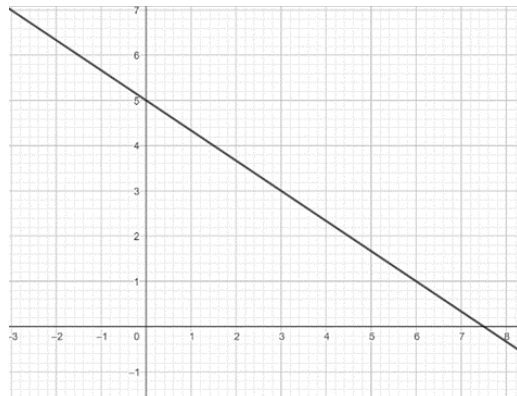

--	--

- b) Pema wants to estimate the amount of wax needed to make crayon. About how many cubic centimetre of wax are needed to make this crayon. [3]

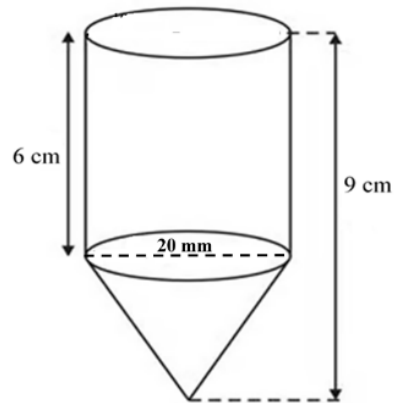

--	--

c) Sherab is purchasing a new laptop for Nu 60,000 and he has been offered two options: [2]

**Option A:** Pay Nu 2,750 at the end of each month, for a period of one year.

**Option B:** The amount will be paid semi-annually for the period of one year with the interest rate of 12%.

Which option is better for Sherab and why?

--	--

- d) An open box can be made by cutting equal squares out of the corners and folding up the edges of a square sheet of cardboard as shown in the diagram below. What is the length of each side of the cardboard sheet if the volume of the box is to be 50 cubic centimetre? [3]

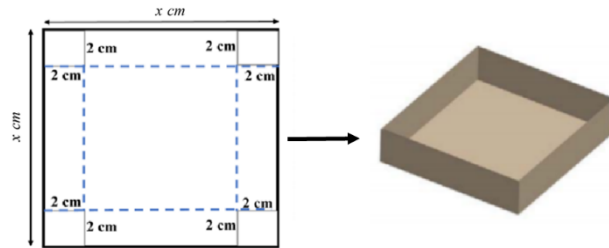

Blank area for the student's solution.

**Question 7**

a) Explain different types of symmetry of a regular hexagon?

**[2]**

--	--

b) A square based solid structure with a single point at the top has a fixed volume of 1000 cubic meter. The side length of the base is twice its height. Calculate the dimensions.

**[3]**

--	--

- c) Five years ago, Pema's age was seven times that of her son. Five years from now, her age will be three times that of her son. What are their present ages? [3]

--	--

- d) If the cost of the plastic material needed to cover the roof of green house is Nu 15 per square meter, what is the total amount required to cover the entire roof? [2]

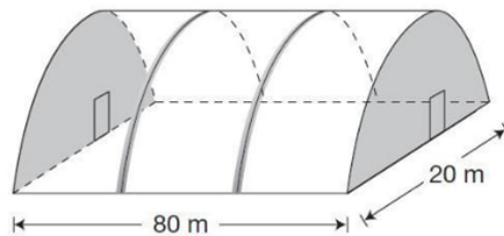

--	--

**Question 8**

- a) The length BD is an altitude of triangle ABC. Find the measure  $\angle DBC$  and  $\angle DCB$ . [2]

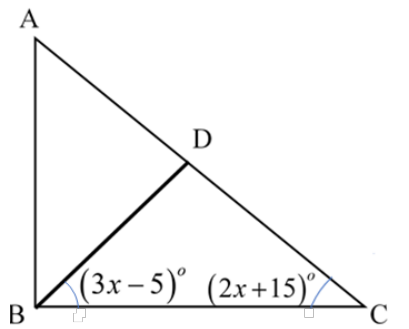

--	--

b) The table presents scores of 11 students in Mathematics and English Examination.

<b>Mathematics</b>	37	65	18	76	38	40	66	93	52	75	48
<b>English</b>	75	45	85	19	85	69	54	34	29	32	56

i. Create a scatter plot of the data.

[1]

--	--

ii. Using the scatter plot, predict the English mark of a student who scored 60 in Mathematics. Draw the line of best fit on the scatter plot and use it to make your prediction.

[2]

--	--

iii. What type of correlation is shown?

[1]

--	--

- c) Study the cone and the sphere given below. The cone has height  $h$  cm. The radius of the base of the cone is 3 times the radius of the sphere. Given that the volume of the sphere is equal to the volume of the cone, find an expression for the radius of the sphere in terms of  $h$ . [2]

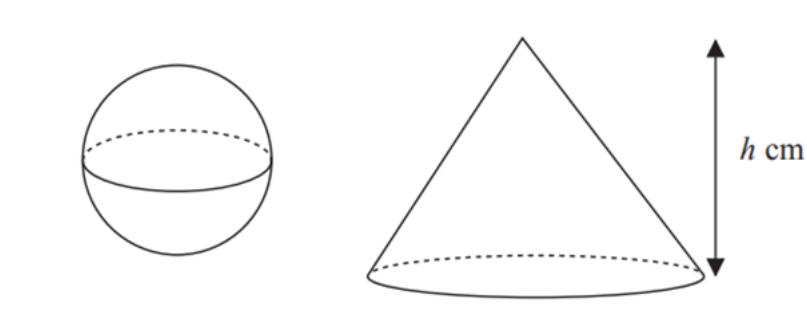

--	--

d) Prove the following:

i.  $\sec x - \tan x \sin x = \frac{1}{\sec x}$

[1]

--	--

ii.  $\tan x \cot x - \sin^2 x = \cos^2 x$

[1]

--	--

**Question 9**

- a) Write the equation using the pair of roots  $(x - 4)$  and  $(x + 3)$ . Identify the coefficients from the equation. [2]

--	--

- b) The following data shows the scores of students in a test: [3]

10, 20, 5, 15, 25, 8, 30

Find the third quadrant and what does the value indicate about the students' scores.

--	--

- c) If A, B, C are 2 x 2 matrices. Can  $A(B+C)$  and  $(B+C)A$  be equal? Justify using the given matrices. **[3]**

$$A = \begin{bmatrix} 1 & 2 \\ 3 & 4 \end{bmatrix} \quad B = \begin{bmatrix} 0 & 1 \\ 1 & 0 \end{bmatrix} \quad C = \begin{bmatrix} 2 & 0 \\ 0 & 2 \end{bmatrix}$$

d) If  $x = \sqrt{48}$ ,  $y = \sqrt{36x^m}$  and  $q = 24x^7\sqrt{3x}$ , evaluate the value of  $m$  if  $x \times y = q$ . [2]

--	--

## FORMULAE

### Strand A : Numbers and Operations

$$SI = prt \text{ or } \frac{PRT}{100}$$

$$A = p \left( 1 + \frac{r}{n} \right)^{nt} \text{ or } p \left( 1 + \frac{r}{n \times 100} \right)^{nt}$$

$$DA = fv \times r \times n$$

$$\text{Yield\%} = \frac{DA}{OI} \times 100\%$$

### Strand B : Patterns and Algebra

$$f(x) = ax^2 + bx + c$$

$$f(x) = a(x - p)(x - q)$$

$$f(x) = a(x - h)^2 + v$$

### Strand C : Measurement

Volume:

$$V_{\text{rectangular prism}} = lwh$$

$$V_{\text{cube}} = e^3$$

$$V_{\text{any prism}} = Ah$$

$$V_{\text{pyramid}} = \frac{Ah}{3}$$

$$V_{\text{cylinder}} = \pi r^2 h$$

$$V_{\text{cone}} = \frac{\pi r^2 h}{3}$$

$$V_{\text{sphere}} = \frac{4}{3} \pi r^3$$

Surface Area:

$$SA_{\text{rectangular prism}} = 2(lw + wh + lh)$$

$$SA_{\text{cube}} = 6s^2$$

$$SA_{\text{any prism}} = 2A + hP$$

$$SA_{\text{pyramid}} = A + \text{Area of lateral faces}$$

$$SA_{\text{cylinder}} = 2\pi r^2 + 2\pi rh$$

$$SA_{\text{cone}} = \pi r^2 + \pi rs$$

$$SA_{\text{sphere}} = 4\pi r^2$$

### Strand E : Data management and probability

$$\text{Mean} = \frac{\sum fx}{\sum f}$$

$$Q_1 = L + \frac{i}{f} \left( \frac{n}{4} - c \right)$$

$$Q_2 = L + \frac{i}{f} \left( \frac{n}{2} - c \right)$$

$$Q_3 = L + \frac{i}{f} \left( \frac{3n}{4} - c \right)$$

Rough work

Rough work

Rough work